

TOP VIEW

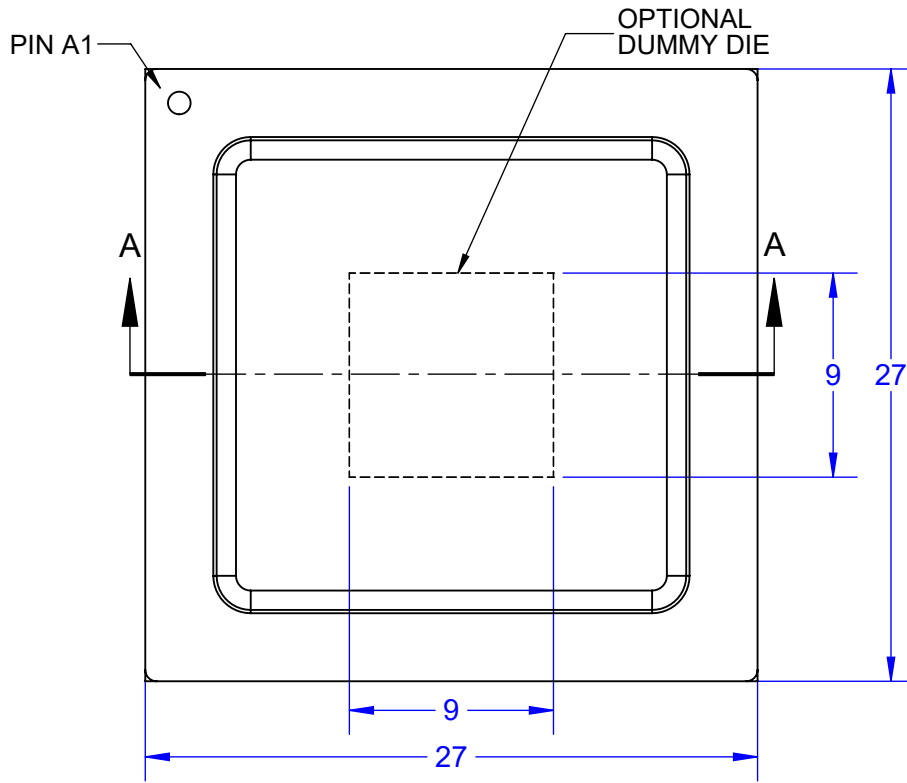

BALL VIEW

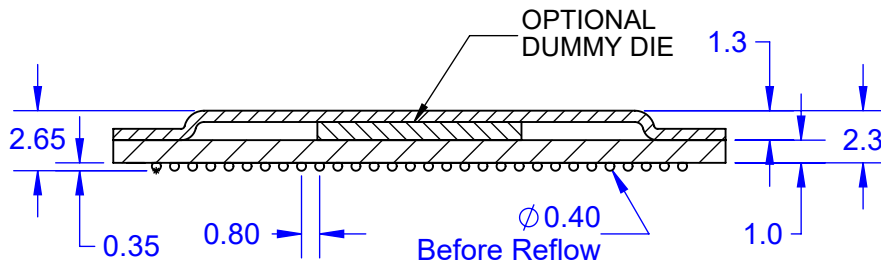
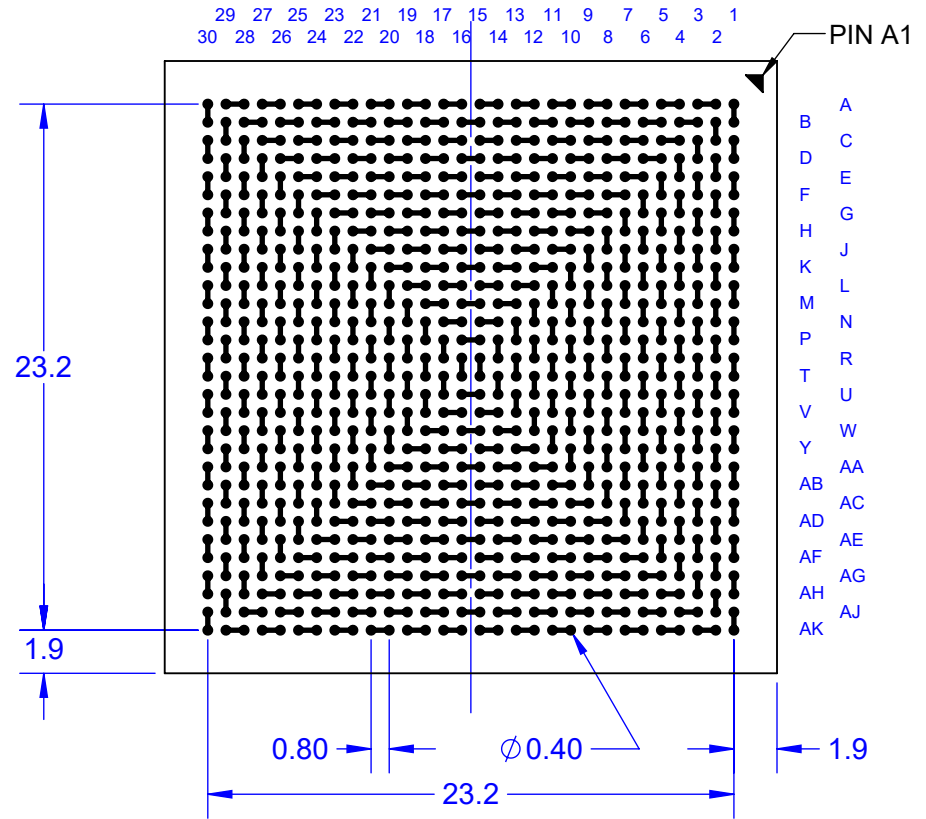

SECTION A-A

Notes: (Unless Otherwise Specified).

- 1) ALL DIMENSIONS ARE IN MM.
- 2) SOLDER BALL ALLOY: SEE PART NUMBER TABLE.
- 3) BALL DIAMETER (BEFORE REFLOW): 0.40mm.
- 4) SOLDER MASK DEFINED PAD OPENING: 0.33mm (13 MIL).
- 5) PAD Cu DIAMETER: 0.508mm (20 MIL).
- 6) SUBSTRATE MATERIAL: BT.
- 7) DUMMY DIE IS OPTIONAL.
- 8) DAISY CHAIN PATTERN (SEE PAGE 2).
- 9) MSL-3 RECOMMENDED BAKING 24 HOURS @ 125°C TO REMOVE MOISTURE PRIOR SOLDERING TO PC BOARD.

PART NUMBER TABLE

PART NUMBER	BALL ALLOY	Pb-FREE	RoHS	Si DIE
SBGA900T.8C-DC309D	Sn96.5/Ag3.0/Cu0.5	YES	YES	YES
SBGA900T.8-DC309D	Sn63/Pb37	NO	NO	YES

APPROVALS	DATE				
DRAWN T.Au	2/14/2023				
ENG M. Hart	2/14/2023	TITLE		SBGA900T.8-DC309D DAISY CHAIN DUMMY	
MFG		SCALE	SIZE	DRAWING NO.	REV
QA		3:1	A	583095	B
CUST		DO NOT SCALE DRAWING			SHEET 1 OF 5
REVISED					

BALL VIEW

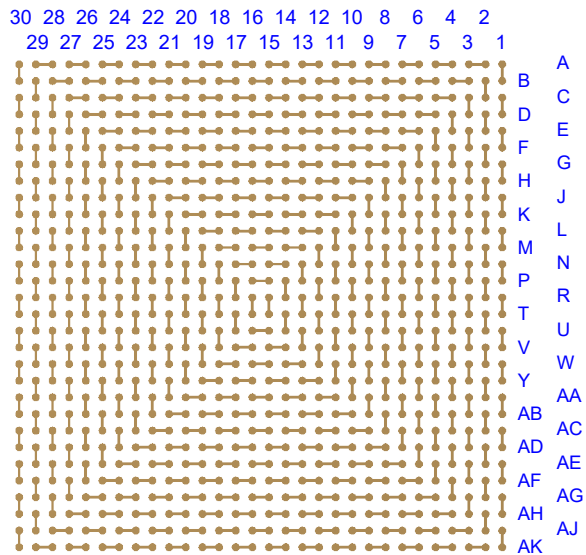

BOTTOM SIDE (TOP X-RAY VIEW)

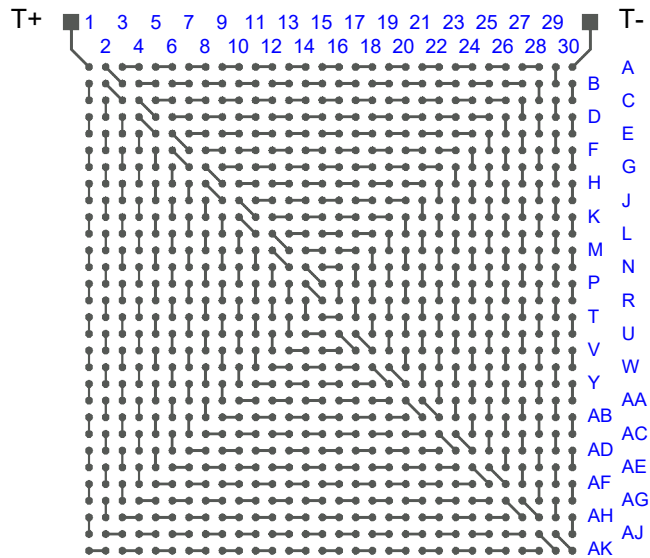
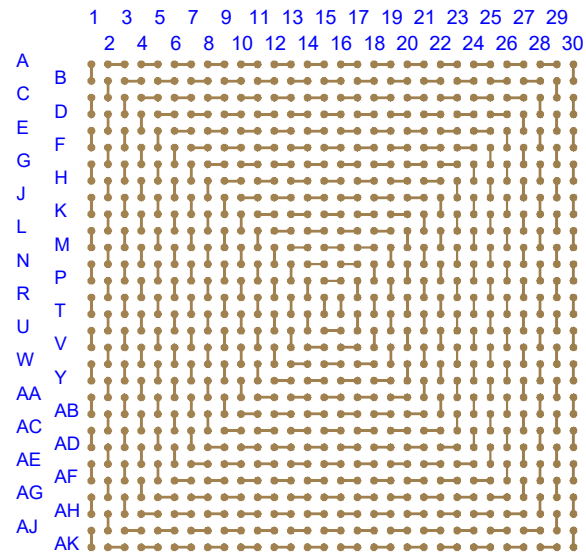

TEST VEHICLE BOARD

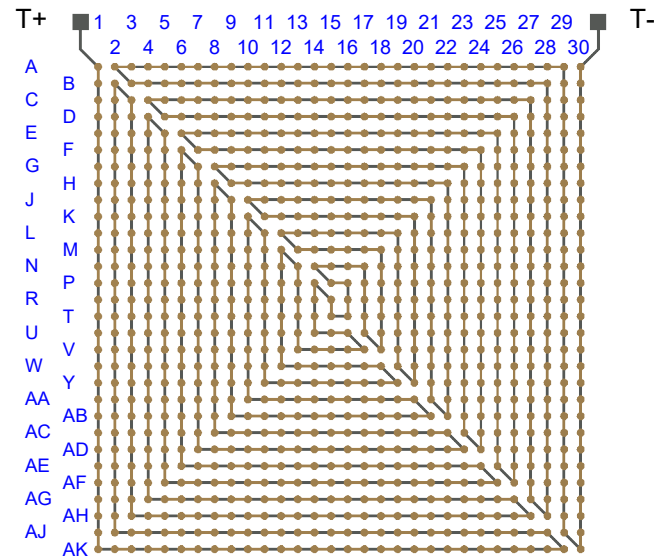

AFTER MOUNTING

Notes:

- 1) PCB BOARD DIMENSIONS ARE PRESENTED ONLY AS A GUIDELINE. DESIGNERS SHOULD USE THEIR OWN EXPERIENCE WHEN DESIGNING PCB.
- 2) PCB Cu BALL PAD DIAMETER 0.508mm (20 MIL).
- 3) PCB DAISY CHAIN TRACING LINE WIDTH 0.152mm (6 MIL).
- 4) SMD (SOLDER MASK DEFINED) PAD OPENING: 0.33mm (13 MIL).

TopLine®			
TITLE		SBGA900T.8-DC309D DAISY CHAIN DUMMY	
SCALE	SIZE	DRAWING NO.	REV
3:1	A	583095	B
DO NOT SCALE DRAWING			SHEET 2 OF 5

MODEL

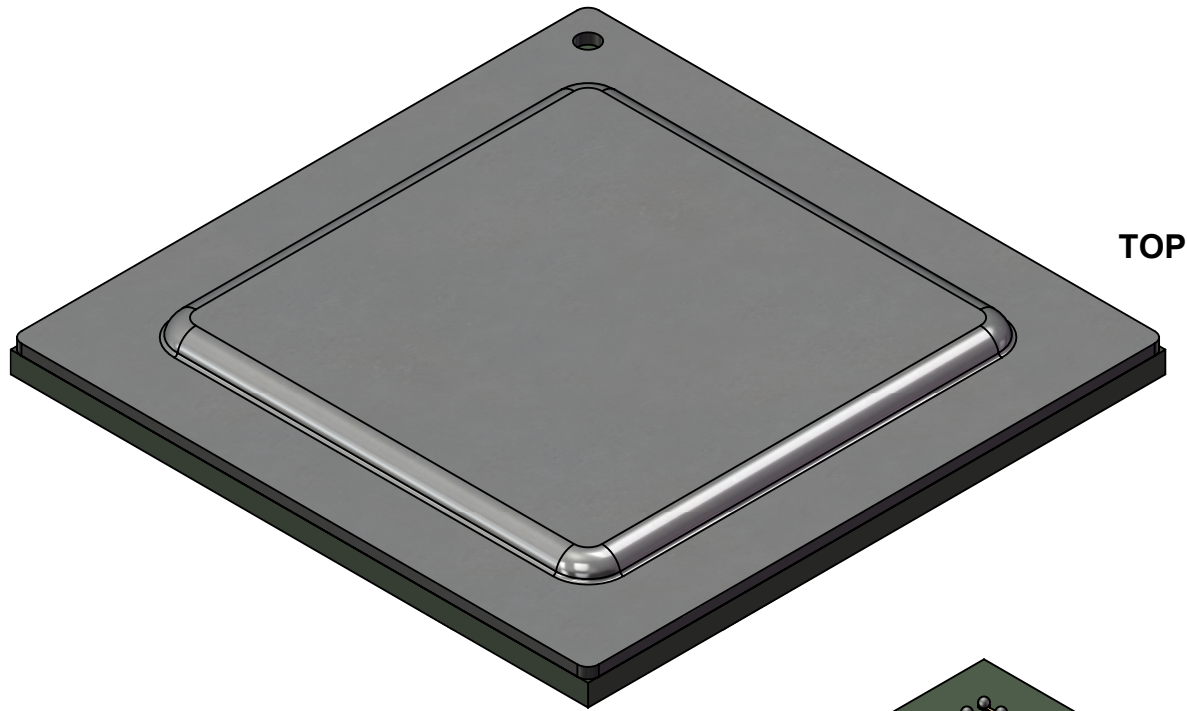

TOP

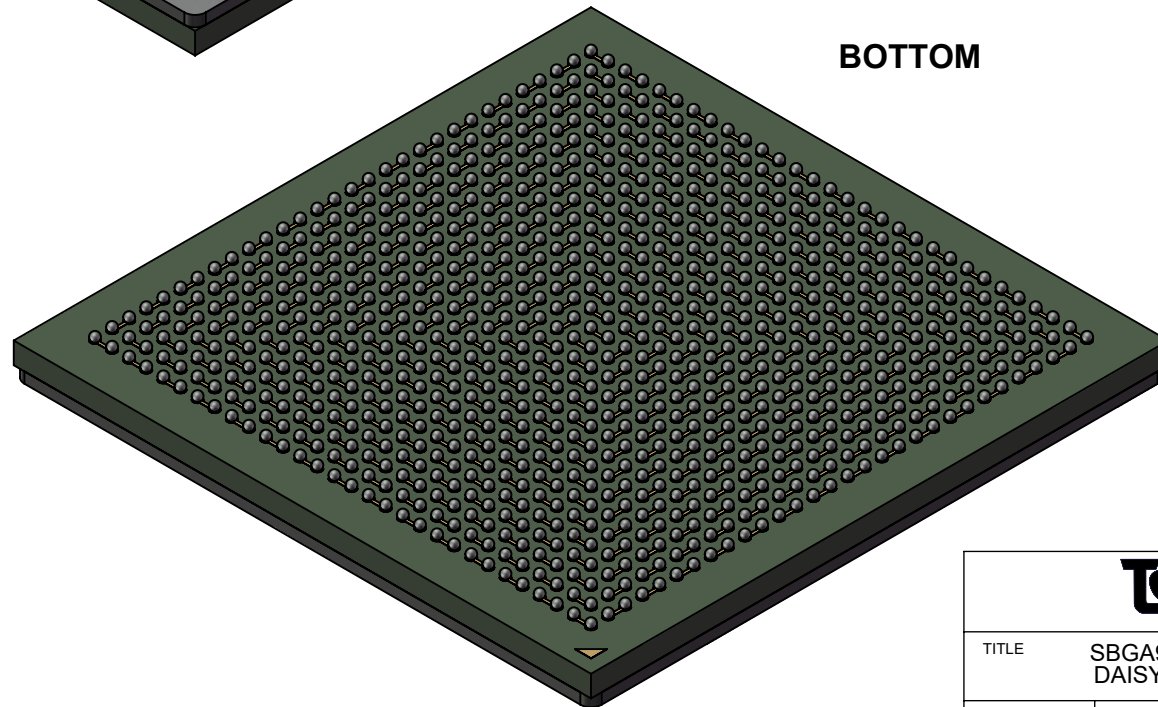

BOTTOM

TopLine[®]

TITLE SBGA900T.8-DC309D
DAISY CHAIN DUMMY

SCALE 3:1	SIZE A	DRAWING NO. 583095	REV B
--------------	-----------	-----------------------	----------

DO NOT SCALE DRAWING

SHEET 3 OF 5

HEAT SPREADER

TOP

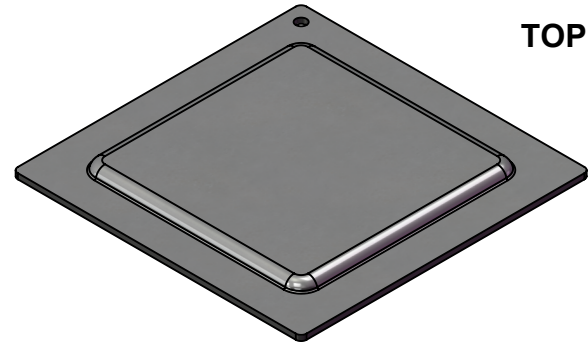

MODEL

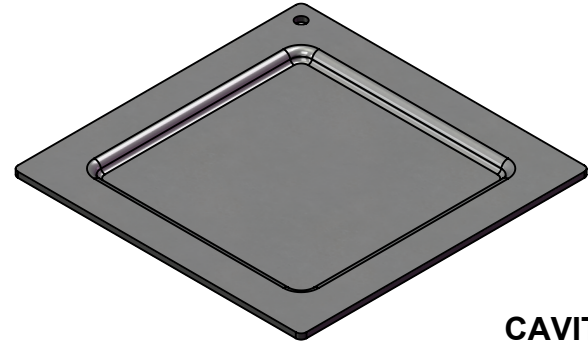

CAVITY

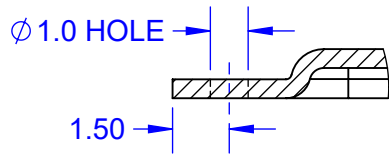
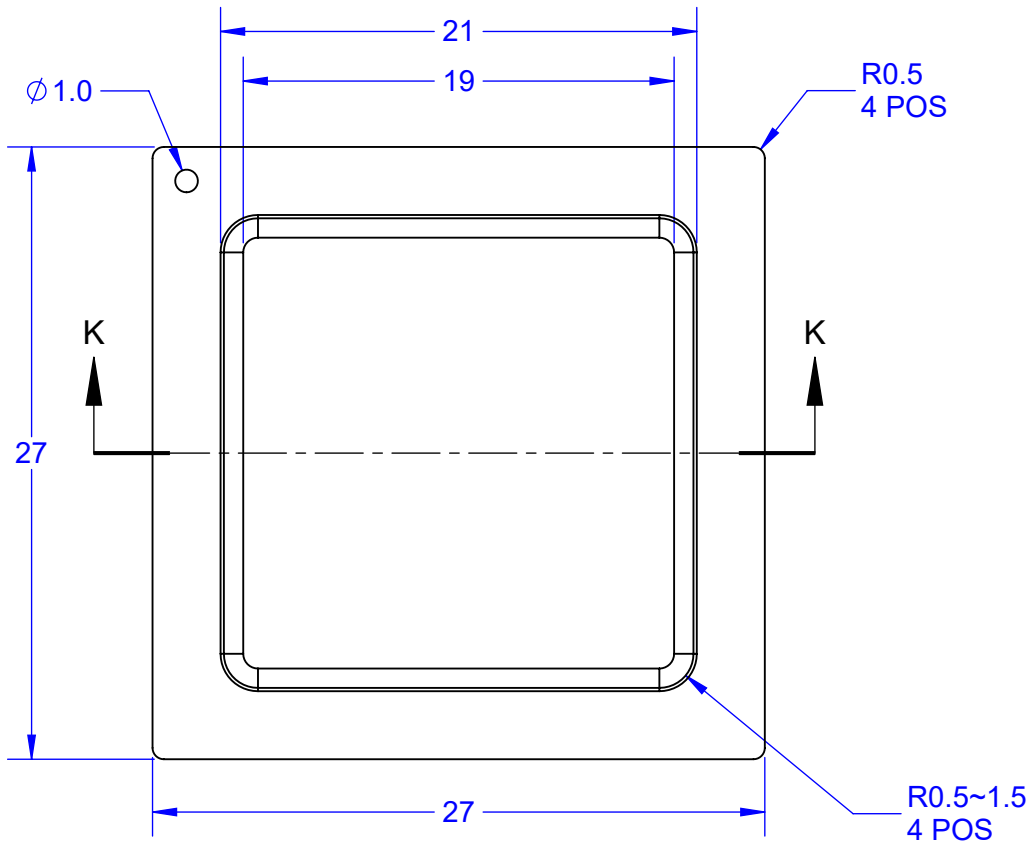

DETAIL B
SCALE 5 : 1

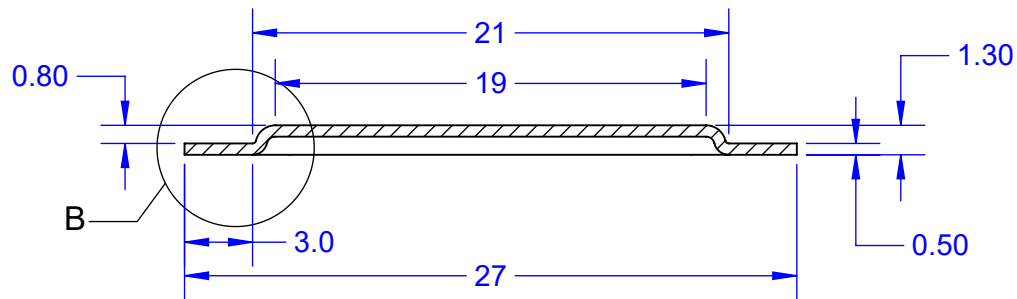

SECTION K-K
SCALE 3 : 1

APPROVALS	DATE	TopLine®			
DRAWN T. Au	2/14/2023				
ENG M. Hart	2/14/2023	TITLE H-CAP27A DOME LID			
MFG		SCALE 2.5:1	SIZE A	DRAWING NO. 227710	REV A
QA		DO NOT SCALE DRAWING			SHEET 4 OF 5
CUST					
REVISED					

BOTTOM SOLDERMASK (RIGHT READING)

30 28 26 24 22 20 18 16 14 12 10 8 6 4 2
29 27 25 23 21 19 17 15 13 11 9 7 5 3 1

A
B
C
D
E
F
G
H
J
K
L
M
N
P
R
T
U
V
W
Y
AA
AB
AC
AD
AE
AF
AG
AH
AJ
AK

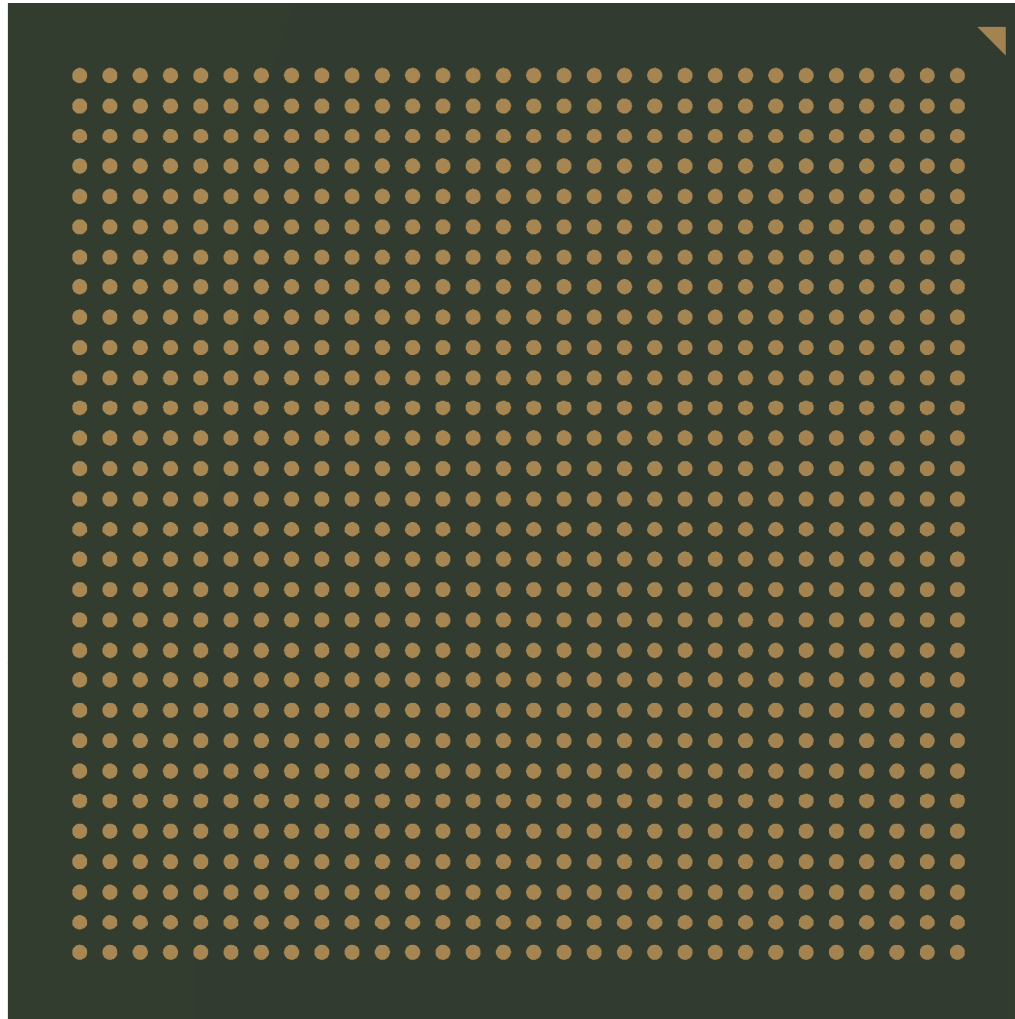

TopLine[®]			
TITLE		SBGA900T.8-DC309D DAISY CHAIN DUMMY	
SCALE	SIZE	DRAWING NO.	REV
3:1	A	583095	B
DO NOT SCALE DRAWING			SHEET 5 OF 5